



CONSOLIDATED SEWING MACHINE CORP.

└ INDUSTRIAL SEWING & CUTTING EQUIPMENT

Model

226R-2

Parts List

www.southstarsupply.com

INDEX

	Pages
面板、上板 FACE PLATE, ARM TOP COVER	1, 2
天ビン、上軸、プーリー TAKE UP LEVER, ARM SHAFT, MACHINE PULLEY	3, 4
押工棒、中押工棒 PRESSER BAR, VIBRATING PRESSER BAR	5, 6
針棒土台、連結ロッド NEEDLE BAR ROCK FRAME, ROCK SHAFT CRANK CONNECTION	7, 8
大弓、押工棒大板バネ KNEE LIFTER LIFTING LEVER, PRESSER BAR SPRING	9, 10
下軸、下ベルトプーリー、送りカム HOOK DRIVING SHAFT, SAFETY CLUTCH PULLEY, FEED DRIVING CAM	11, 12
針板、送り土台、送り軸 THROAT PLATE, FEED BAR, FEED ROCK SHAFT	13, 14
バックレバー、下送りロッド FEED REVERSING LEVER, FEED DRIVING ECCENTRIC CONNECTION	15, 16
カマ土台、カマ HOOK SADDLE, HOOK	17, 18
調子板 TENSION	19, 20
附属品 ACCESSORIES AND ATTACHMENTS	21, 22
別売品 PARTS AVAILABLE AT EXTRA CHARGE	23, 24

面板、上板
FACE PLATE, ARMTOP COVER

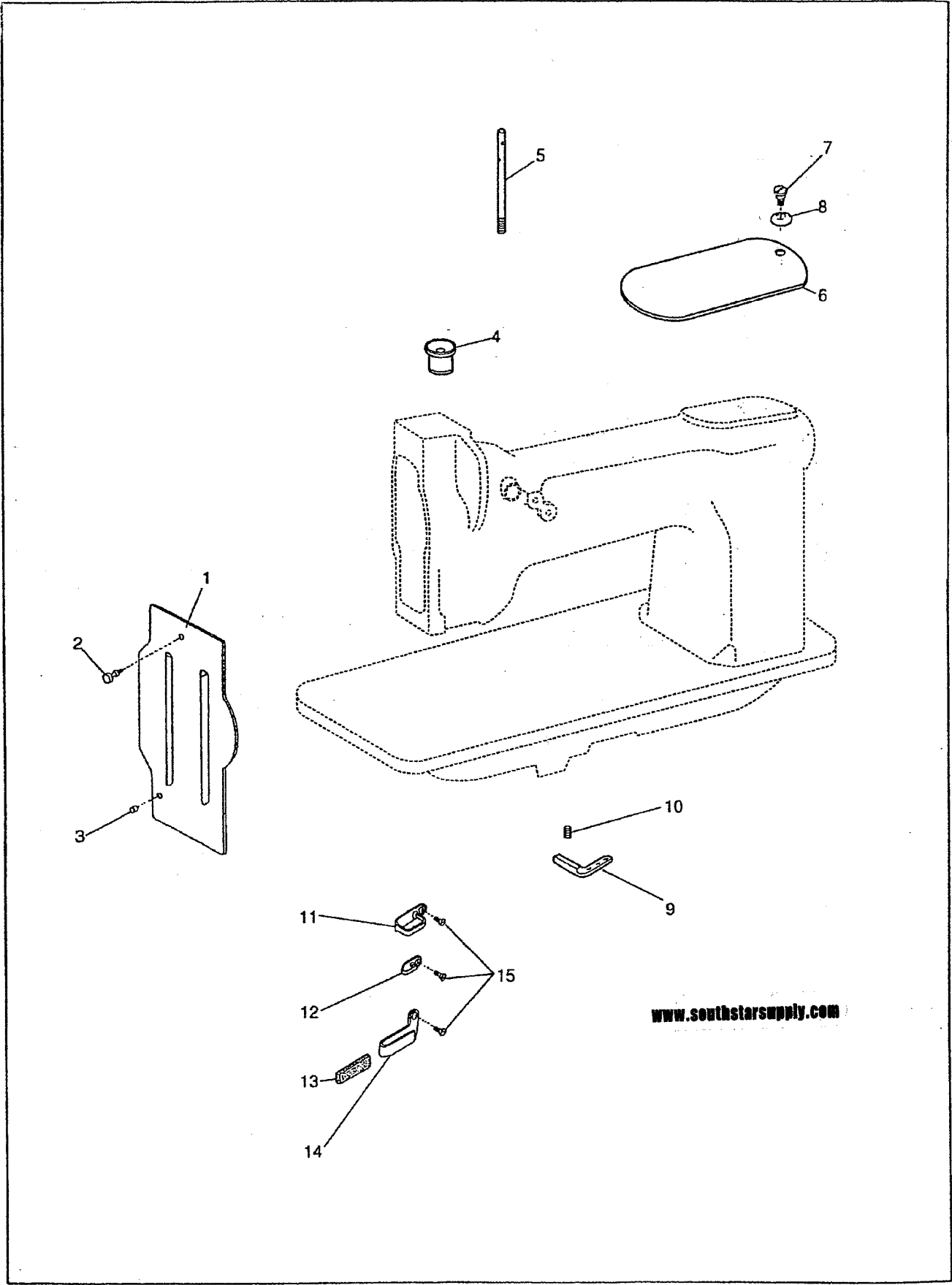

www.southstarsupply.com

面板、上板
FACE PLATE, ARM TOP COVER

NO	部品番号 PART NO	数量 QTY	品名	PARTS NAME
1	10698	1	面板	FACE PLATE
2	10699	1	止めねじ	SCREW 3.4X36 L=4.5
3	10700	1	ピン	PIN
4	10701-A	1	油栓	RUBBER
5	10709	1	糸立棒	ARM SPOOL PIN
6	10702	1	上板	ARM TOP COVER
7	10704	1	上板段ねじ	HINGE SCREW 3/16X28
8	10703	1	上板ワッシャー	WASHER
9	10680	1	三ッ穴糸掛け	THREAD RETAINER
10	10681	1	止めねじ	SCREW 3.4X36 L=6.5
11	10682	1	面糸掛 (上)	THREAD GUIDE (UPPER)
12	10683	1	面糸掛 (中)	THREAD GUIDE (MIDDLE)
13	10760	1	フェルト	FELT
14	10759-A	1	面下掛 (下)	THREAD GUIDE (LOWER)
15	10685	3	止めねじ	SCREW 3.4X36 L=6.5

www.southstarsupply.com

天ピン、上軸、プーリー
 TAKE UP LEVER, ARM SHAFT, MACHINE PULLEY

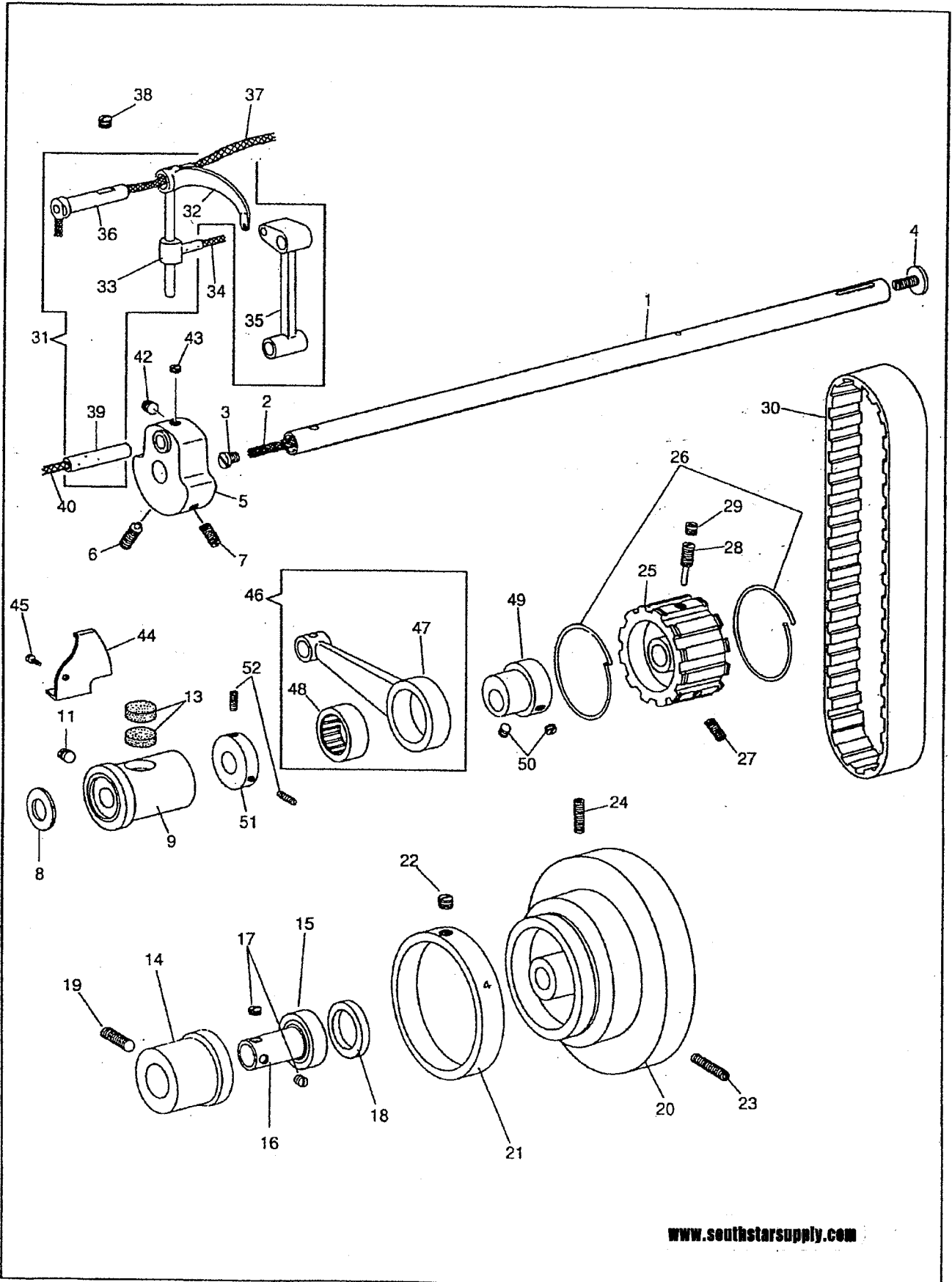

www.southstarsupply.com

天ピン、上軸、プーリー

TAKE UP LEVER, ARM SHAFT, MACHINE PULLEY

NO	部品番号 PART NO	数量 QTY	品名	PARTS NAME
1	10768	1	上軸	ARM SHAFT
2	11042	1	上軸油芯	OIL WICK
3	10506	1	上軸油栓 ねじ	OIL STOP SCREW 7.85X20 L=6.0
4	10577	1	プーリー押しねじ	PULLEY ADJUSTING SCREW 6.75X24 L=11.0
5	19414	1	クランクモーションカム	NEEDLE BAR CRANK
6	19415	1	位置決めねじ	POSITION SCREW 1/4X28 L=20.0
7	19416	1	止めねじ	SET SCREW 1/4X28 L=14.0
8	10563	1	上軸メタル (前) ワッシャ	WASHER
9	10562	1	上軸メタル (前)	ARM SHAFT BUSHING (FRONT)
10				
11	10522	1	止めねじ	SET SCREW 6.75X24 L=14.0
12				
13	10725	2	上軸メタル (前) フェルト	OIL FELT
14	13074	1	上軸ベアリングケース	ARM SHAFT BALL BEARING ADAPTOR
15	10567	1	上軸ベアリング	ARM SHAFT BALL BEARING
16	10565	1	上軸ベアリングカラー	ARM SHAFT BALL BEARING ADAPTOR SLEEVE
17	10566	2	止めねじ	SET SCREW 1/4X32 L=5.5
18	10568	1	溝なしリング	BALL BEARING RETAINING RING
19	10571	1	上軸ベアリングケース止めねじ	SCREW 6.75X24 L=20.0
20	10504	1	プーリー	MACHINE PULLEY
21	10847-B	1	文字リング (ベルトガード無用)	FEED INDICATING DISC (W/O BELT GUARD)
21	10847-A	(1)	文字リング (ベルトガード付用)	FEED INDICATING DISC (W/
22	10566	1	文字リング 止めねじ	SET SCREW 1/4X32 L=5.5
23	10576	1	位置決めねじ	POSITION SCREW 15/64X28 L=21.0
24	10579	1	止めねじ	SET SCREW 15/64X28 L=20.0
25	10569	1	ベルトプーリー	ARM SHAFT CONNECTING BELT PULLEY
26	10574	2	ベルトプーリーリング	BELT PULLEY SPRING FLANGE
27	10571-G	1	ベルトプーリー止めねじ	SET SCREW 6.75X24 L=20.0
28	10570	1	ベルトプーリーピンねじ	POSITION SCREW 6.75X24 L=14.5
29	10524-G	1	ベルトプーリーピンねじ止めねじ	POSITION SCREW SET SCREW 6.75X24 L=6.5
30	10621	1	タイミングベルト	ARM SHAFT CONNECTING BELT
31	10526C	1	天秤 (組)	THREAD TAKE UP LEVER COMPLETE
32	10526	1	天秤	THREAD TAKE UP LEVER
33	10529	1	天秤抱き	THREAD TAKE UP LEVER DRIVING STUD
34	10728	1	天秤抱き油芯	OIL WICK
35	10528	1	針棒クランク	NEEDLE BAR CONNECTING LINK
36	10527	1	天秤ピン	THREAD TAKE UP LEVER HINGE STUD
37	11042	1	天秤ピン油芯	OIL WICK
38	10525	1	天秤ピン止めねじ	SET SCREW 6.75X24 L=9.0
39	10523	1	針棒クランクピン	NEEDLE BAR CONNECTING LINK STUD
40	10726	1	針棒クランクピン油芯	OIL WICK
42	19417	1	針棒クランクピン 止めねじ (長)	SCREW 1/4X28 L=6.5
43	19418	1	針棒クランクピン 止めねじ (短)	SCREW 1/4X28 L=4.5
44	10551	1	天秤油受け	THREAD TAKE UP LEVER OIL GUARD
45	10650	1	天秤油受け止めねじ	SCREW 3.4X36 L=6.0
46	10772C	1	上連結ロッド (組)	LIFTING ECCENTRIC CONNECTION COMPLETE
47	10772	1	上連結ロッド	LIFTING ECCENTRIC CONNECTION
48	10773	1	ニードルベアリング	NEEDLE BEARING
49	19427	1	中押え上下カム	LIFTING ECCENTRIC
50	19508	2	中押え上下カム止めねじ	SET SCREW 1/4X40 L=5.5
51	11879	1	中押え上下カムカラー	LIFTING ECCENTRIC COLLAR
52	10573	2	中押え上下カムカラー止めねじ	SET SCREW 7/32X32 L=11.0

www.southstarsupply.com

押工棒、中押工棒
 PRESSER BAR, VIBRATING PRESSER BAR

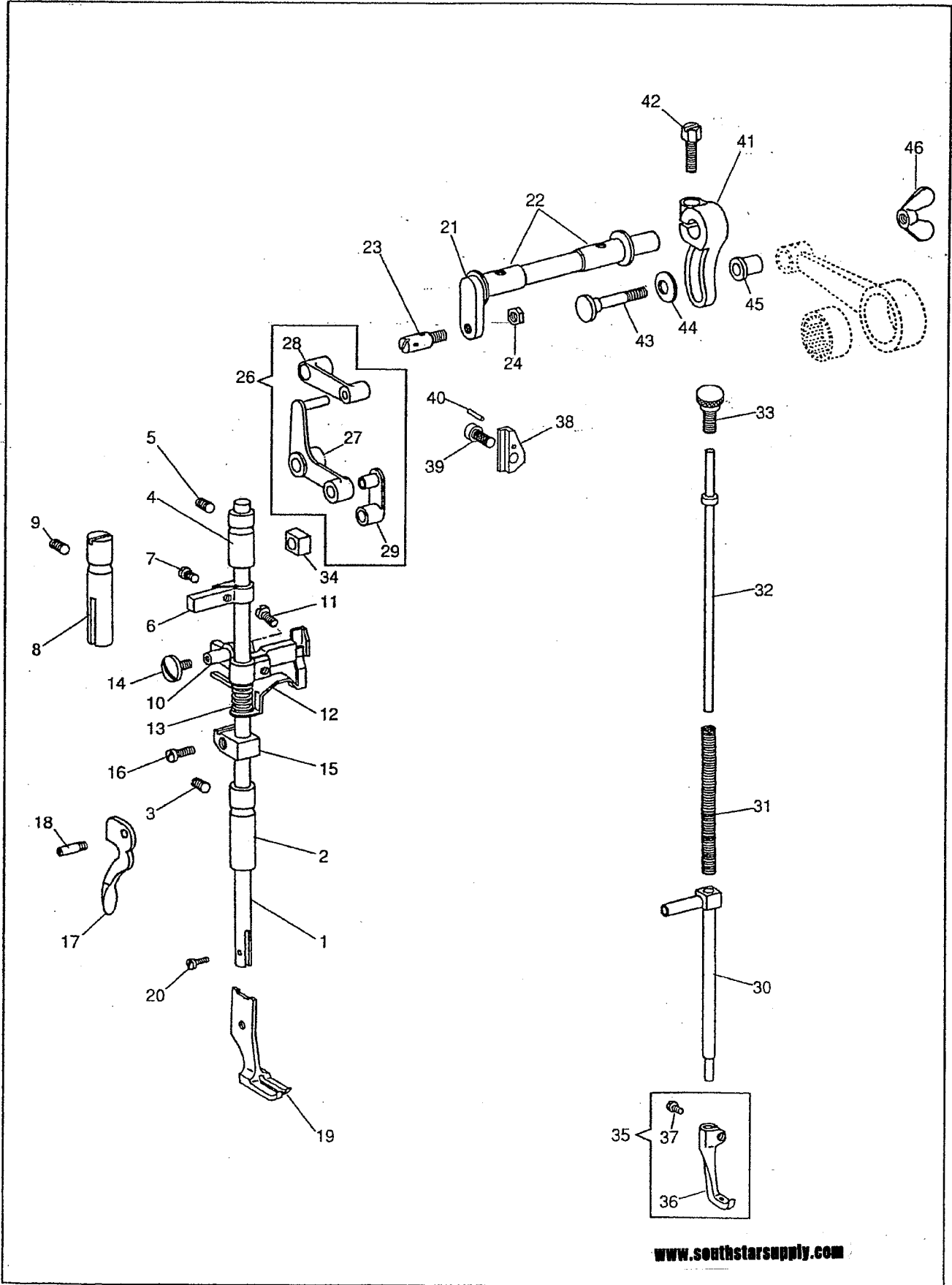

押工棒、中押工棒

PRESSER BAR, VIBRATING PRESSER BAR

NO	部品番号 PART NO	数量 QTY	品名	PARTS NAME
1	10540	1	押え棒	PRESSER BAR
2	10539-A	1	押え棒 (下) メタル	PRESSER BAR BUSHING (LOWER)
3	10761	1	止めねじ	SET SCREW 6.75X24 L=11.0
4	10538	1	押え棒 (上) メタル	PRESSER BAR BUSHING (UPPER)
5	10761	1	止めねじ	SET SCREW 6.75X24 L=11.0
6	10541	1	押え棒案内	PRESSER BAR POSITION GUIDE BRACKET
7	10662	1	止めねじ	SCREW 5/32X40 L=6.5
8	10543	1	案内棒	PRESSER BAR POSITION GUIDE
9	10761	1	止めねじ	SET SCREW 6.75X24 L=11.0
10	18479	1	押え棒抱き	PRESSER BAR LIFTING BRACKET
11	19518	1	押え棒抱き締めねじ	SCREW 11/64X40 L=14.0
12	10546-A	1	押え棒抱き下板	TENSION RELEASE SLIDE
13	10547	1	押え棒抱き下板ばね	TENSION RELEASE SPRING
14	18480	1	くの字止めねじ	LIFTING BELL CRANK SCREW 11/64X40 L=8.0
15	13360	1	押え棒抱きリング	PRESSER BAR SPRING BRACKET
16	13365	1	押え棒抱きリング締めねじ	SCREW M4X0.7 L=9.0
17	10659	1	押え上げレバー	PRESSER BAR LIFTER
18	10660	1	押え上げレバーピンねじ	HINGE SCREW 4.5X32
19	10796	1	外押え	LIFTING PRESSER FOOT
20	10664	1	外押え止めねじ	SCREW 3.4X36 L=9.0
21	19425	1	横軸	LIFTING ROCK SHAFT
22	10514	2	横軸メタル	LIFTING ROCK SHAFT BUSHING
23	19515	1	横軸ピンねじ	SCREW 1/4X28
24	19516	1	横軸ピンねじナット	NUT 1/4X28
25				
26	10558C	1	くの字セット	LIFTING BELL CRANK COMPLETE
27	10558	1	くの字	LIFTING BELL CRANK
28	10557	1	くの字連結 (大)	LIFTING BELL CRANK LINK
29	10556	1	くの字連結 (小)	VIBRATING PRESSER BAR CONNECTING LINK
30	34713	1	中押え棒	VIBRATING PRESSER BAR
31	10554	1	中押えスプリング	VIBRATING PRESSER BAR EXTENSION SPRING
32	10553-A	1	中押えスプリング棒	VIBRATING PRESSER BAR EXTENSION
33	10708	1	中押え棒押しねじ	SCREW 7/32X32
34	15118	1	振れ止角玉	VIBRATING PRESSER BAR SLIDE BLOCK
35	19411C	1	中押え (組)	VIBRATING PRESSER FOOT COMPLETE
36	19411	1	中押え	VIBRATING PRESSER FOOT
37	17104	1	中押え止めねじ	PINCH SCREW 11/64X40 L=6.0
38	10548-A	1	押え棒抱き振れ止め板	LIFTING BRACKET GUIDE BLOCK
39	10519	1	止めねじ	SCREW 6.75X24 L=17.5
40	15111	1	ピン	PIN
41	19419	1	上下カム連結だるま	LIFTING ECCENTRIC CONNECTING CRANK
42	19420	1	上下カム連結だるま締めねじ	PINCH SCREW 1/4X28 L=16.0
43	10775	1	上連結ロッド段ねじ	HINGE SCREW 7/32X32
44	10703	1	上連結ロッド段ねじワッシャー	WASHER
45	10774	1	上連結ロッドパイプ	LIFTING ECCENTRIC CONNECTION COLLAR
46	10776	1	上連結ロッド蝶ナット	NUT 7/32X32

www.southstarsupply.com

針棒土台、連結ロッド

NEEDLE BAR ROCK FRAME, ROCK SHAFT CRANK CONNECTION

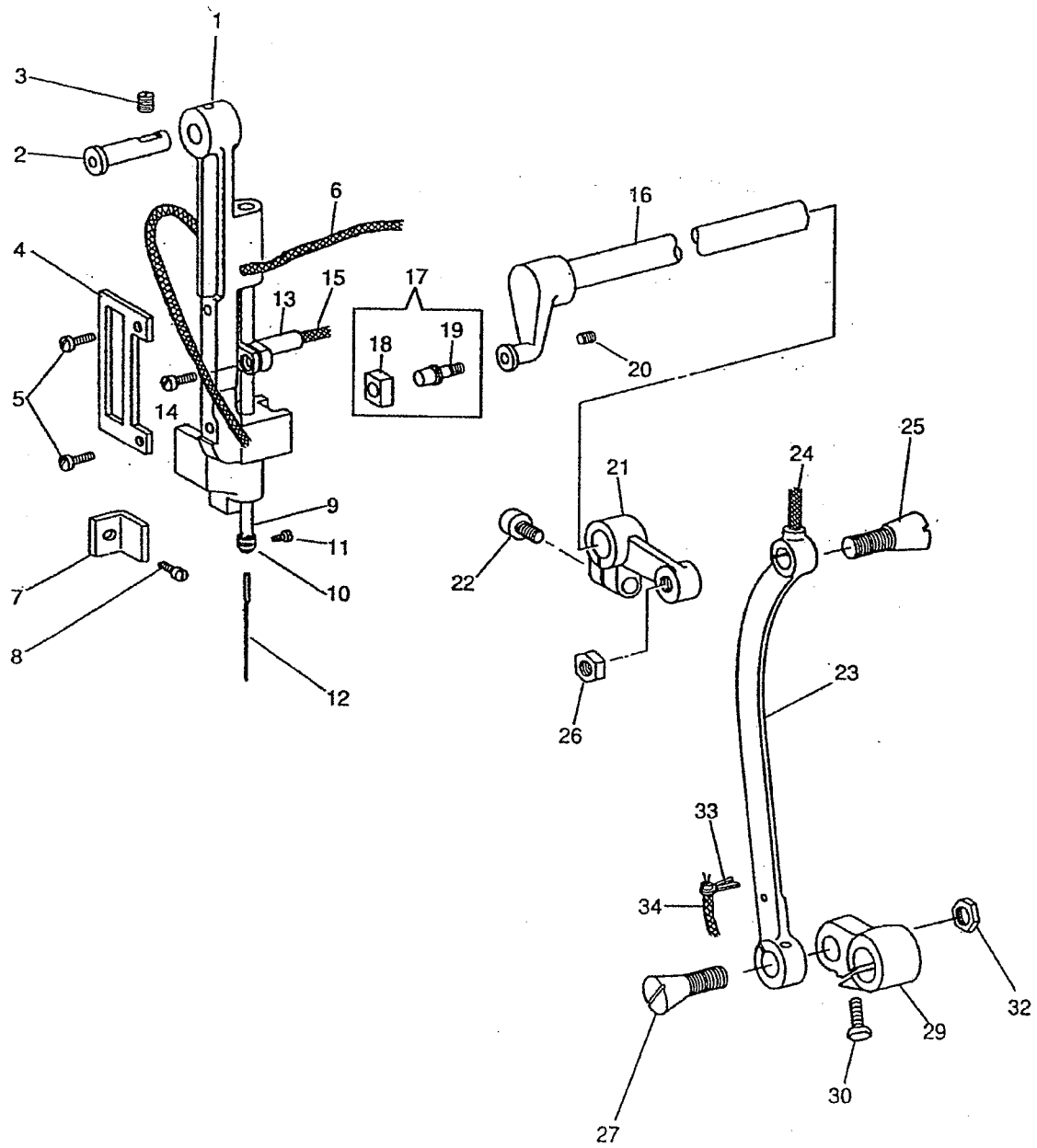

www.southstarsupply.com

針棒土台、連結ロッド

NEEDLE BAR ROCK FRAME, ROCK SHAFT CRANK CONNECTION

NO	部品番号 PART NO	数量 QTY	品名	PARTS NAME
1	15110-A	1	針棒土台	NEEDLE BAR ROCK FRAME
2	11875	1	針棒土台ピン	HINGE STUD
3	10525	1	止めねじ	SET SCREW 6.75X24 L=9.0
4	15117	1	振れ止板	SLIDE BLOCK PLATE
5	8100	2	振れ止板止めねじ	SCREW 9/64X40 L=6.5
6	15031	1	針棒土台油芯	OIL WICK
7	10560	1	イケール	NEEDLE BAR ROCK FRAME POSITION BRACKET
8	10561	1	止めねじ	SCREW 11/64X32 L=6.5
9	19413	↑	針棒	NEEDLE BAR
10	10533	1	針棒糸掛	NEEDLE BAR THREAD GUIDE
11	B140553	1	針止めねじ	NEEDLE SET SCREW 1/8X40 L=4.5
12	N0122	1	針	NEEDLE
13	19426	1	針棒抱き	NEEDLE BAR CONNECTING STUD
14	13365	1	針棒抱き締めねじ	PINCH SCREW M4X0.7 L=9.0
15	10726	1	針棒抱き油芯	OIL WICK
16	10578	1	上送り竿	NEEDLE BAR ROCK FRAME ROCK SHAFT
17	11876C	1	上送り竿角玉 (組)	SLIDE BLOCK COMPLETE
18	11877	1	上送り竿角玉	SLIDE BLOCK
19	11876	1	上送り竿ピンねじ	SLIDE BLOCK STUD
20	10581	1	上送り竿ピンねじ止めねじ	SET SCREW 7/32X32 L=7.0
21	10755	1	連結	ROCK SHAFT CRANK
22	10519	1	連結締めねじ	PINCH SCREW 6.75X24 L=17.5
23	10756	1	連結ロッド	ROCK SHAFT CRANK CONNECTION
24	10728	1	連結ロッド油芯	OIL WICK
25	8014	1	連結ロッド皿ねじ (小)	HINGE SCREW 9/32X28 L=13.1
26	8105	1	連結ロッド皿ねじ (小) ナット	NUT 9/32X28
27	10758	1	連結ロッド皿ねじ (大)	HINGE SCREW 11/32X28 L=26.0
28				
29	10757	1	送り竿後だるま	FEED ROCK SHAFT CRANK
30	10754	1	送り竿後だるま締めねじ	PINCH SCREW 6.75X24 L=16.0
31				
32	3036	1	連結ロッド皿ねじ (大) ナット	NUT 11/32X28
33	10779	1	油芯押え割ピン	CLIP
34	10778	1	油芯	OIL WICK
35				
36				

www.southstarsupply.com

大弓、押工棒大板バネ
KNEE LIFTER LIFTING LEVER, PRESSER BAR SPRING

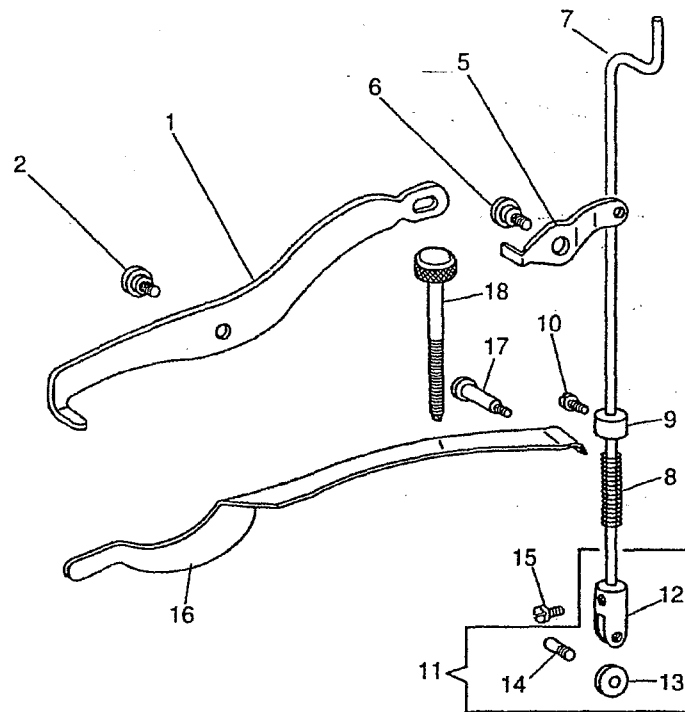

www.southstarsupply.com

大弓、押工棒大板バネ

KNEE LIFTER LIFTING LEVER, PRESSER BAR SPRING

NO	部品番号 PART NO	数量 QTY	品名	PARTS NAME.
1	10710	1	大弓	KNEE LIFTER LIFTING LEVER
2	10712	1	大弓止めねじ	HINGE SCREW 6.75X24
3				
4				
5	10711	1	小弓	KNEE LIFTER CONNECTING LEVER
6	10712	1	小弓止めねじ	HINGE SCREW 6.75X24
7	10713-A	1	吊り棒	KNEE LIFTER CONNECTING LEVER LIFTING ROD
8	10716	1	吊り棒スプリング	SPRING
9	10714	1	吊り棒カラー	LIFTING ROD COLLAR
10	10561	1	吊り棒カラー止めねじ	SET SCREW 11/64X32 L=6.5
11	10717C	1	吊り棒土台(組)	LIFTING ROD ROLLER BRACKET COMPLETE
12	10717	1	吊り棒土台	LIFTING ROD ROLLER BRACKET
13	10718	1	吊り棒土台ローラー	LIFTING ROD ROLLER
14	10719	1	吊り棒土台ローラー止めねじ	SCREW 3.4X36
15	10561	1	吊り棒土台止めねじ	SCREW 11/64X32 L=6.5
16	10705	1	押え棒大板ばね	PRESSER BAR SPRING (FLAT)
17	10706	1	大板ばね受けねじ	PRESSER BAR SPRING SUPPORT SCREW 6.75X24
18	10707	1	大板ばね調節ねじ	PRESSER BAR SPRING REGULATING SCREW

www.southstarsupply.com

下軸、下ベルトプーリー、送りカム

HOOK DRIVING SHAFT, SAFETY CLUTCH PULLEY, FEED DRIVING CAM

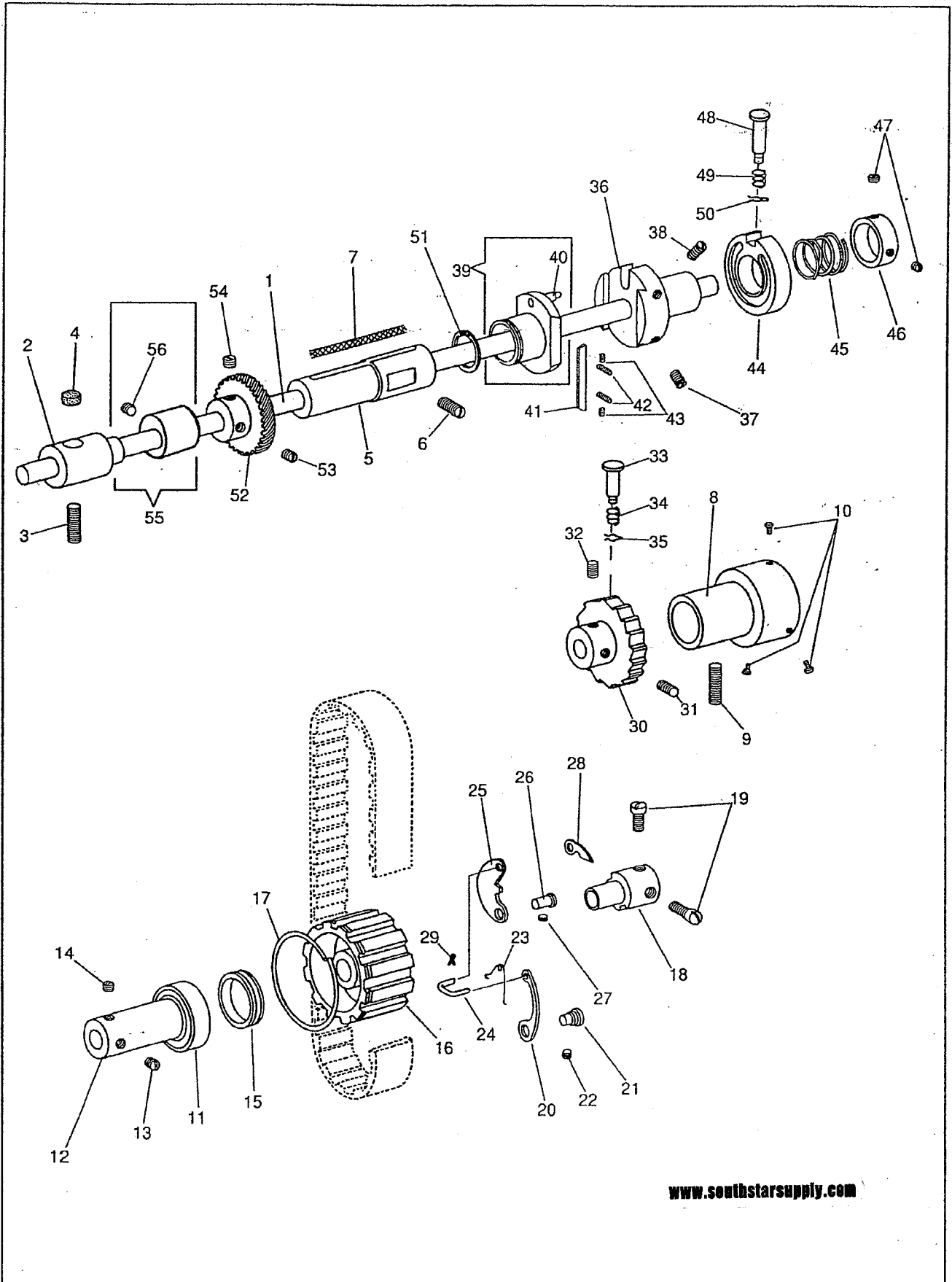

www.southstarsupply.com

下軸、下ベルトプーリー、送りカム

HOOK DRIVING SHAFT, SAFETY CLUTCH PULLEY, FEED DRIVING CAM

NO	部品番号 PART NO	数量 QTY	品名	PARTS NAME
1	10603	1	下軸	HOOK DRIVING SHAFT
2	10782	1	下軸 (前) メタル	HOOK DRIVING SHAFT BUSHING (FRONT)
3	10571	1	止めねじ	SET SCREW 6.75X24 L=20.0
4	11080	1	下軸 (前) メタルフェルト	OILING FELT
5	10605	1	下軸 (中間) メタル	HOOK DRIVING SHAFT BUSHING (MIDDLE)
6	10522	1	止めねじ	SET SCREW 6.75X24 L=14.0
7	10729	1	メタル油芯	OIL WICK
8	30157	1	下軸ベアリングケース	HOOK DRIVING SHAFT BUSHING (BACK)
9	10571	1	止めねじ	SET SCREW 6.75X24 L=20.0
10	10609	3	溝付リング止めねじ	SCREW 3.4X36 L=5.0
11	10567	1	下軸ベアリング	BALL BEARING
12	10607	1	下軸ベアリングカラー	COLLAR
13	10566	1	止めねじ	SET SCREW 1/4X32 L=5.5
14	10658	1	位置決めねじ	POSITION SCREW 1/4X32 L=5.5
15	10608	1	溝付リング	BALL BEARING RETAINING WASHER
16	10610-01	1	下ベルトプーリー	SAFETY CLUTCH PULLEY
17	10574	1	プーリーリング	PULLEY SPRING FLANGE
18	10611	1	下ベルトプーリー心棒	SAFETY CLUTCH COLLAR
19	10612	2	止めねじ	SCREW 1/4X32 L=10.5
20	10615	1	下ベルトプーリー板ばね	SAFETY CLUTCH LOCKING LEVER SPRING
21	10614	1	下ベルトプーリー段ピン	HINGE PIN
22	10581	1	下ベルトプーリー段ピン止めねじ	SCREW 7/32X32 L=7.0
23	10619	1	下ベルトプーリースプリング	SAFETY CLUTCH THROW IN LATCH SPRING
24	10618	1	下ベルトプーリー小連結	SAFETY CLUTCH RATCHET CONNECTING LINK
25	10616	1	下ベルトプーリー掛金	SAFETY CLUTCH LOCKING LEVER
26	10613	1	下ベルトプーリー掛金ピン	HINGE STUD
27	10581	1	掛金ピン止めねじ	SCREW 7/32X32 L=7.0
28	10617	1	下ベルトプーリー小爪	SAFETY CLUTCH RATCHET
29	10620	1	下ベルトプーリー割ピン	SAFETY CLUTCH THROW IN LATCH PIN
30	10622	1	爪車	HOOK DRIVING SHAFT LOCK RATCHET
31	10766	1	止めねじ	SET SCREW 1/4X32 L=7.0
32	10639	1	位置決めねじ	POSITION SCREW 1/4X32 L=8.0
33	10672	1	押しボタン (小)	FEED REGULATING STUD (SMALL)
34	10673	1	スプリング	SPRING
35	10674	1	止メピン	CLIP
36	10627	1	送りカム土台	FEED DRIVING FLANGE
37	10765	1	止めねじ	SET SCREW 1/4X32 L=11.0
38	10628	1	位置決めねじ	POSITION SCREW 1/4X32 L=12.0
39	15022	1	送りカム	FEED DRIVING CAM
40	10634	1	送りカムかしめピン	FEED DRIVING ECCENTRIC PIN
41	10631	1	カミソリ	FEED DRIVING ECCENTRIC FRICTION GIB
42	10629	2	止めねじ	SCREW 1/8X40 L=8.0
43	10630	2	位置決めねじ	POSITION SCREW 1/8X40 L=5.0
44	10909-E	1	渦巻きカム	FEED DRIVING ECCENTRIC ADJUSTING DISC
45	10625	1	押しリングスプリング	SPRING
46	10623	1	押しリング	COLLAR
47	10566	2	止めねじ	SET SCREW 1/4X32 L=5.5
48	10671	1	押しボタン (大)	FEED REGULATING STUD (LARGE)
49	10673	1	スプリング	SPRING
50	10674	1	止めピン	CLIP
51	15023	1	止め輪	RETAINING RING
52	10638	1	大ギヤー	HOOK DRIVING GEAR
53	10639	1	位置決めねじ	POSITION SCREW 1/4X32 L=8.0
54	10766	1	止めねじ	SET SCREW 1/4X32 L=7.0
55	10637	1	送り上下カムねじ付	FEED LIFTING CAM COMPLETE
56	10658	1	止めねじ	SET SCREW 1/4X32 L=5.5

www.southstarsupply.com

針板、送り土台、送り軸
THROAT PLATE, FEED BAR, FEED ROCK SHAFT

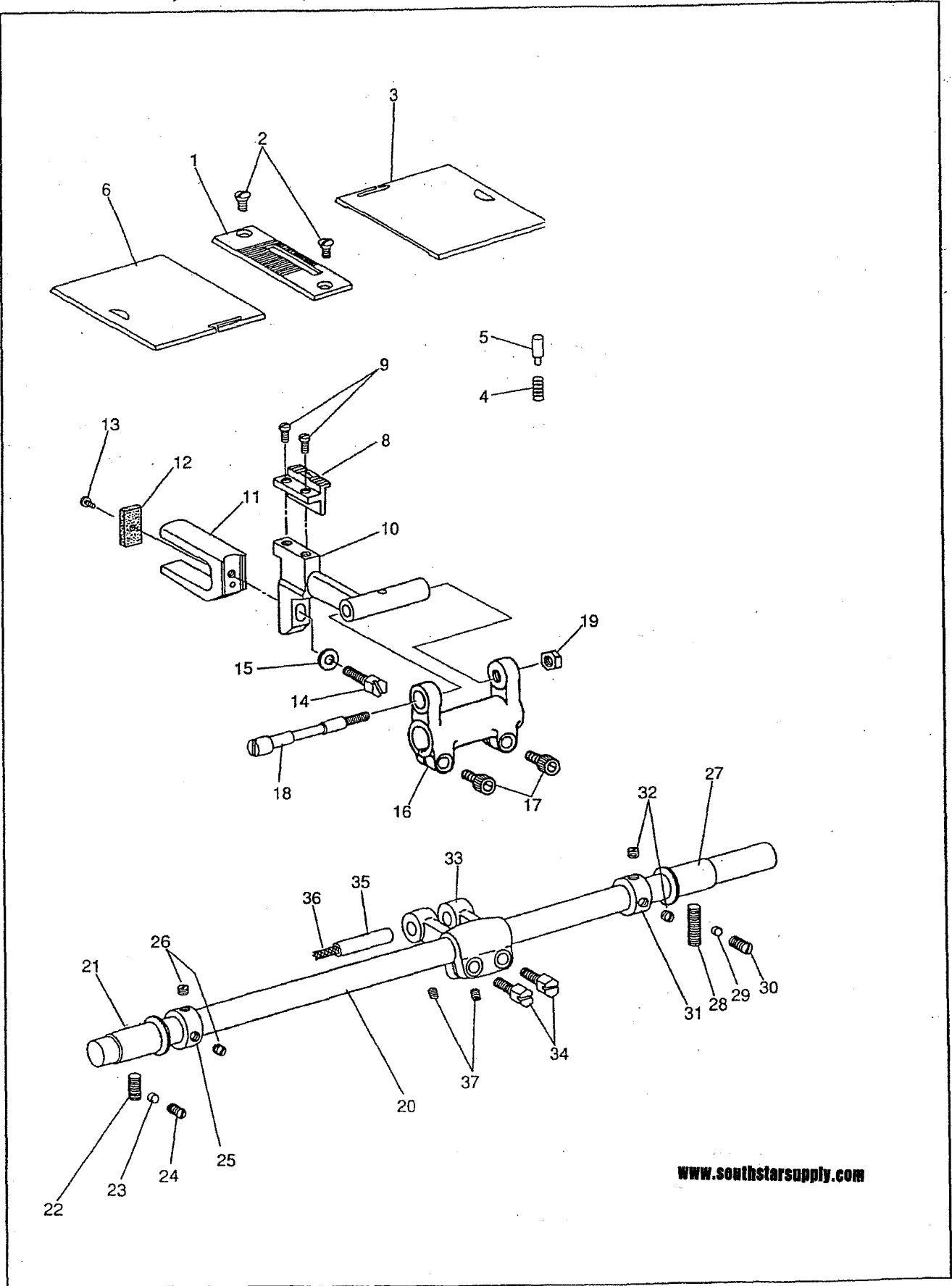

www.southstarsupply.com

針板、送り土台、送り軸

THROAT PLATE, FEED BAR, FEED ROCK SHAFT

NO	部品番号 PART NO	数量 QTY	品名	PARTS NAME
1	10665	1	針板	THROAT PLATE
2	6031-01	2	針板止めねじ	SCREW 11/64X40 L=9.0
3	15056	1	角板(右)	BED SLIDE (RIGHT)
4	10668	1	角板スプリング	SPRING
5	10667	1	角板ピン	PIN
6	10669	1	角板(左)	BED SLIDE (LEFT)
7				
8	10805	1	送り歯	FEED DOG
9	10601	2	送り歯止めねじ	SCREW 1/8X40 L=7.0
10	10594	1	送り土台	FEED BAR
11	10595	1	コの字	FEED LIFTING CAM FORK
12	10596	1	コの字フェルト	OILING FELT
13	10597	1	止めねじ	SCREW 1/8X40 L=3.3
14	70129	1	コの字止めねじ	SET SCREW 7/32X32 L=15.0
15	10599	1	コの字ワッシャー	WASHER
16	16704	1	送り腕	FEED DRIVING ROCK FRAME
17	18065	2	送り腕締めねじ	PINCH SCREW M5X0.8 L=14.0
18	16705	1	送り土台ピンねじ	FEED BAR HINGE PIN
19	16706	1	送り土台ピンねじナット	NUT 1/4X28
20	11888	1	送り軸	FEED ROCK SHAFT
21	10588	1	送り軸メタル(前)	FEED ROCK SHAFT BUSHING (FRONT)
22	10522	1	メタル(前)止めねじ	SCREW 6.75X24 L=14.0
23	11068	1	ライナー	LINER
24	10761	1	メタル(前)止めねじ(補助)	SCREW 6.75X24 L=11.0
25	10593	1	送り軸カラー(前)	COLLAR (FRONT)
26	10764	2	止めねじ	SET SCREW 6.75X24 L=4.5
27	10763	1	送り軸(後)メタル	FEED ROCK SHAFT BUSHING (BACK)
28	10571	1	メタル(後)止めねじ	SCREW 6.75X24 L=20.0
29	11068	1	ライナー	LINER
30	10525	1	メタル(後)止めねじ(補助)	SCREW 6.75X24 L=9.0
31	10593	1	送り軸カラー(後)	COLLAR (BACK)
32	10764	2	止めねじ	SET SCREW 6.75X24 L=4.5
33	16708	1	送り軸前だるま	FEED ROCK SHAFT CRANK
34	19420	2	送り軸前だるま締めねじ	PINCH SCREW 1/4X28 L=16.0
35	11962	1	送り軸前だるまピン	FEED ROCK SHAFT CRANK STUD
36	11954	1	送り軸前だるまピン油芯	OIL WICK
37	11953	2	送り軸前だるまピン止めねじ	SET SCREW 7/32X32 L=5.5

www.southstarsupply.com

バックレバー、下送りロッド
FEED REVERSING LEVER, FEED DRIVING ECCENTRIC CONNECTION

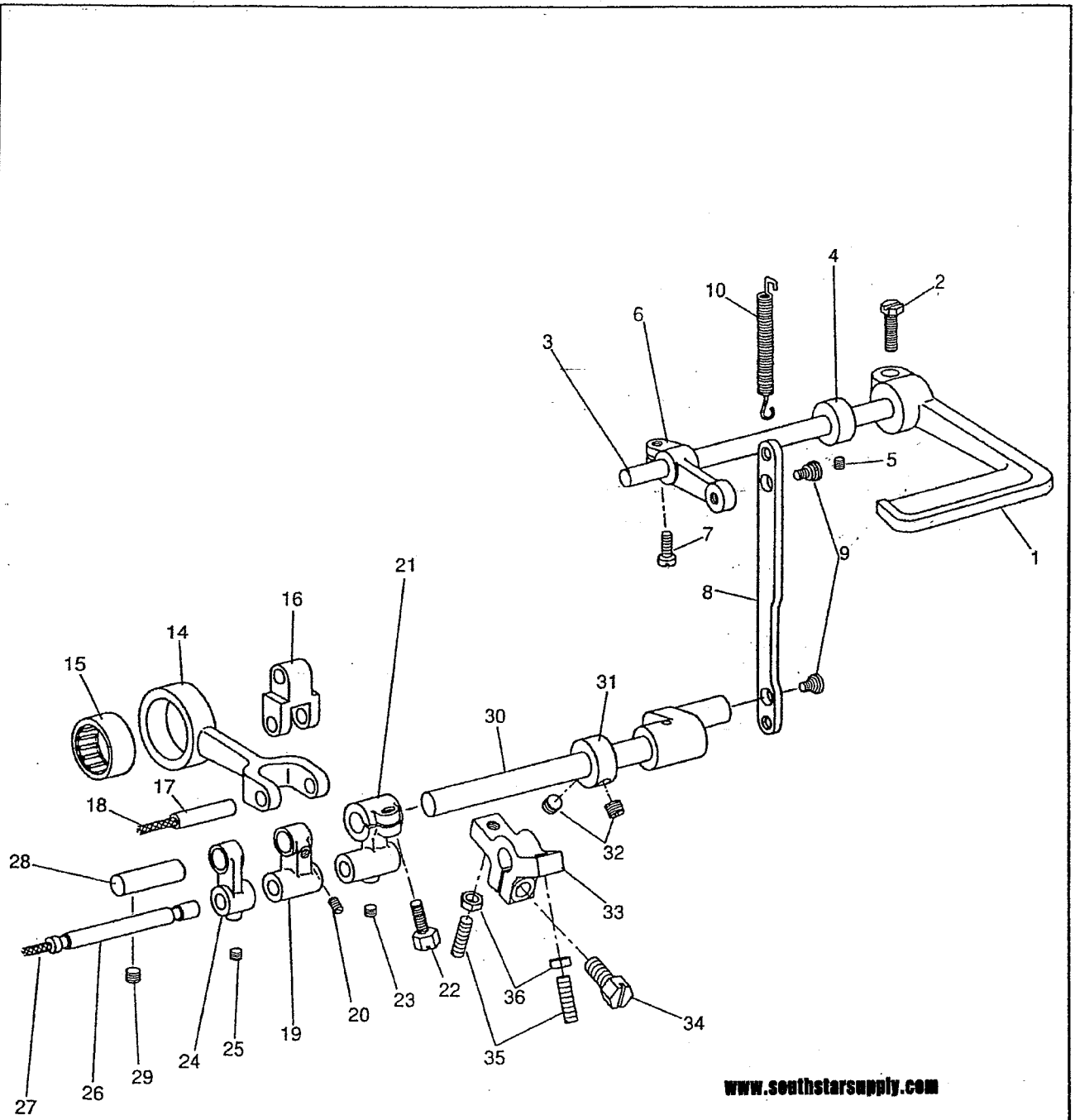

www.southstarsupply.com

バックレバー、下送りロッド

FEED REVERSING LEVER, FEED DRIVING ECCENTRIC CONNECTION

NO	部品番号 PART NO	数量 QTY	品名	PARTS NAME
1	34031	1	バックレバー	FEED REVERSING LEVER
2	10845	1	バックレバー締ねじ	SCREW 15/64X24 L=18.0
3	11970	1	バックレバー軸	FEED REVERSING LEVER SHAFT
4	10802	1	バックレバー軸カラー	COLLAR
5	8009	1	止めねじ	SET SCREW 15/64X28 L=7.5
6	11942	1	レバー軸だるま	FEED REVERSING LEVER SHAFT CRANK
7	1365	1	レバー軸だるま締ねじ	PINCH SCREW 15/64X28 L=16.0
8	11943	1	バック連結ロッド	FEED REVERSING CONNECTION ROD
9	10712	2	バック連結ロッド段ねじ	HINGE SCREW 6.75X24
10	10806	1	バックレバー戻ばね	FEED REVERSING LEVER SPRING
11				
12				
13				
14	11951	1	下送りロッド	FEED DRIVING ECCENTRIC CONNECTION
15	10773	1	下送りロッドニードルベアリング	NEEDLE BEARING
16	11955	1	二又リンク	FEED DRIVING ECCENTRIC CONNECTION LINK
17	11952	1	下送りロッドピン	HINGE PIN
18	11954	1	下送りロッドピン油芯	OIL WICK
19	11956	1	メガネリンク	FEED REVERSING SHAFT CRANK LINK
20	11953	1	メガネリンク止めねじ	SET SCREW 7/32X32 L=5.5
21	16707	1	切換えクランク(右)	FEED REVERSING SHAFT CRANK
22	19420	1	切換えクランク(右) 締ねじ	PINCH SCREW 1/4X28 L=16.0
23	11953	1	切換えクランク(右) 止めねじ	SET SCREW 7/32X32 L=5.5
24	11958	1	切換えクランク(左)	FEED REVERSING MECHANISM SUPPORT LINK
25	11953	1	切換えクランク(左) 止めねじ	SET SCREW 7/32X32 L=5.5
26	31029	1	切換えクランクピン	FEED REVERSING SHAFT CRANK HINGE STUD
27	11960	1	切換えクランクピン油芯	OIL WICK
28	11950	1	切換えクランク(左) 支え軸	FEED REVERSING MECHANISM SUPPORT LINK STUD
29	10766	1	止めねじ	SET SCREW 1/4X32 L=7.0
30	11946C	1	バック土台軸	FEED REVERSING SHAFT
31	11947	1	カラー	COLLAR
32	10566	2	止めねじ	SET SCREW 1/4X32 L=5.5
33	11948	1	バック調節ブラケット	FEED REVERSING SHAFT BRACKET
34	10754	1	バック調節ブラケット止めねじ	SET SCREW 6.75X24 L=16.0
35	11949	2	制限ねじ	STOPPING SCREW M5X0.8 L=18.0
36	4135	2	ナット	NUT M5X0.8

www.southstarsupply.com

カマ土台、カマ
HOOK SADDLE, HOOK

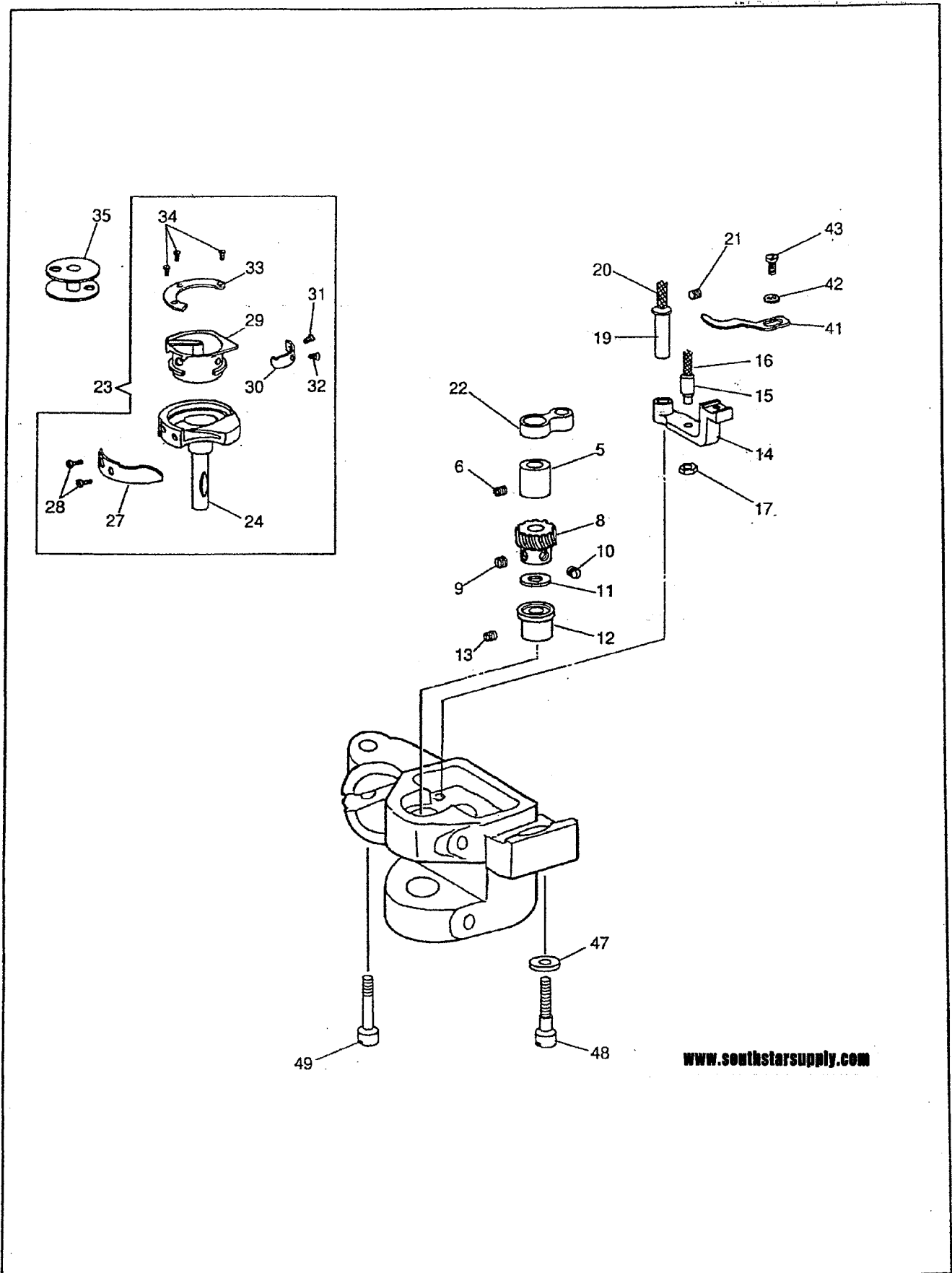

www.southstarsupply.com

カマ土台、カマ
HOOK SADDLE, HOOK

NO	部品番号 PART NO	数量 QTY	品名	PARTS NAME
1	10641	1	カマ土台 (右)	HOOK SADDLE (RIGHT)
2				
3				
4				
5	10642	1	カマ土台メタル (上)	BUSHING (UPPER)
6	10573	1	止めねじ	SEREW 7/32X32 L=11.0
7				
8	10657	1	小ギヤー	HOOK DRIVING PINION (SPIRAL)
9	10658	1	位置決めねじ	POSITION SCREW 1/4X32 L=5.5
10	10767	1	止めねじ	SET SCREW 1/4X32 L=4.5
11	10644	1	ワッシャー	WASHER
12	10643	1	カマ土台メタル (下)	BUSHING (LOWER)
13	10573	1	止めねじ	SCREW 7/32X32 L=11.0
14	10648	1	オープナー土台	BOBBIN CASE OPENER LEVER
15	10651	1	めがねピン	OPENER LEVER DRIVING SCREW STUD
16	10727	1	めがねピンフェルト	FELT
17	10652	1	ナット	NUT 11/64X40
18				
19	10654	1	オープナー土台ピン	OPENER LEVER HINGE STUD
20	10727	1	オープナー土台ピンフェルト	FELT
21	10573	1	止めねじ	SET SCREW 7/32X32 L=11.0
22	10653	1	カマ連結メガネ	BOBBIN CASE LEVER LINK
23	10655	1	カマ (組)	HOOK COMPLETE
24	10655-01	1	外カマ	HOOK
25				
26				
27	10655-05	1	針受板	NEEDLE GUARD
28	16407-06	2	止めねじ	SCREW
29	10655-02	1	内カマ	BOBBIN CASE COMPLETE
30	15040-10	1	糸調子バネ	BOBBIN CASE TENSION SPRING
31	16407-11	1	糸調子バネ止めねじ	SET SCREW
32	16407-12	1	糸調子バネ調子ねじ	TENSION REGULATING SCREW
33	10655-03	1	内カマ押え	HOOK GIB
34	16407-04	3	内カマ押え止めねじ	HOOK GIB SCREW
35	10656	1	ボビン	BOBBIN
36				
37				
38				
39				
40				
41	10649	1	ボビンケースオープナー	BOBBIN CASE OPENER
42	10677	1	ワッシャー	WASHER
43	10650	1	オープナー止めねじ	SEREW 3.4X36 L=6.0
44				
45				
46				
47	10647	1	ワッシャー	WASHER
48	10646	1	カマ土台止めねじ	SCREW 6.75X24 L=28.0
49	10645	1	カマ土台止めねじ	SCREW 7/32X32 L=27.0

www.southstarsupply.com

調子板
TENSION

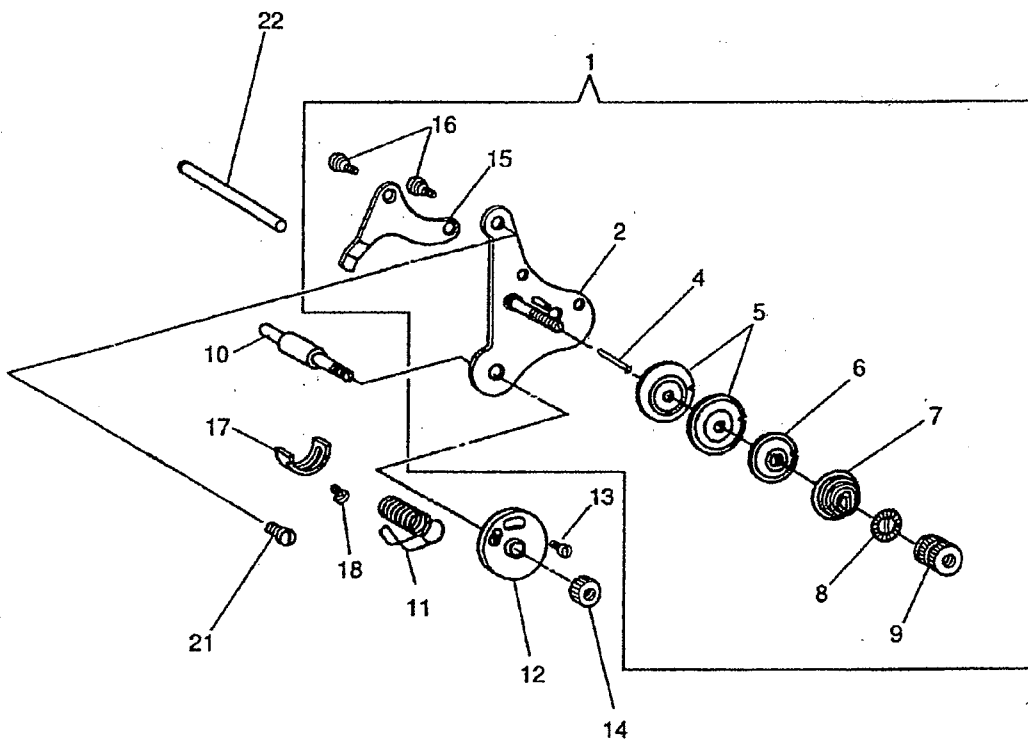

www.southstarsupply.com

調子板
TENSION

NO	部品番号 PART NO	数量 QTY	品名	PARTS NAME
1	19421C-A	1	調子板組 (φ 1. 4)	TENSION BRACKET COMPLETE
2	19421	1	調子板	TENSION BRACKET
3				
4	10793	1	糸ゆるめ段ピン	TENSION RELEASE PIN
5	19531	2	調子皿	TENSION DISC BELT GUARD)
6	19532	1	丸皿	TENSION RELEASE WASHER
7	19533	1	渦巻スプリング (φ 1. 4)	TENSION SPRING
8	28206	1	ローレットストッパー	NUT WASHER
9	19513	1	ローレットナット	NUT 1/4X40
10	19512	1	糸調子棒 (短)	THREAD CONTROLLER STUD
11	10689	1	糸引スプリング	THREAD CONTROLLER SPRING
12	10694	1	二重皿	THREAD CONTROLLER DISC
13	B118319	1	二重皿止めねじ	SCREW 3/32X56 L=6.0
14	19534	1	ローレットナット	NUT 7/32X32
15	10678	1	糸ゆるめ板	TENSION RELEASE PLATE
16	19422	2	糸ゆるめ板段ねじ	SCREW 9/64X40
17	10690	1	スプリング受	THREAD CONTROLLER SPRING STOP
18	10650	1	スプリング受止めねじ	SCREW 3.4X36 L=6.0
19				
20				
21	10561	1	調子板止めねじ	SCREW 11/64X32 L= 6.5
22	10720	1	糸ゆるめピン (長)	TENSION RELEASE PLATE ROD

www.southstarsupply.com

附属品

ACCESSORIES AND ATTACHMENTS

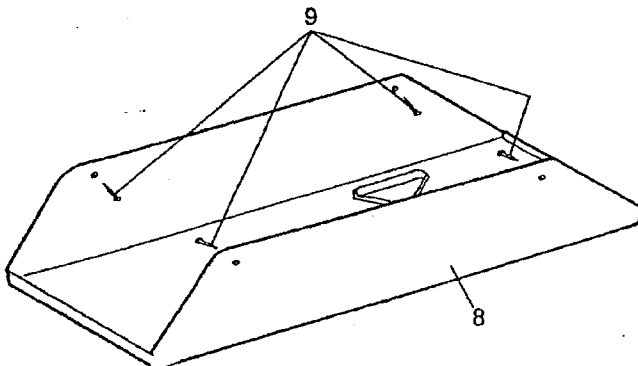
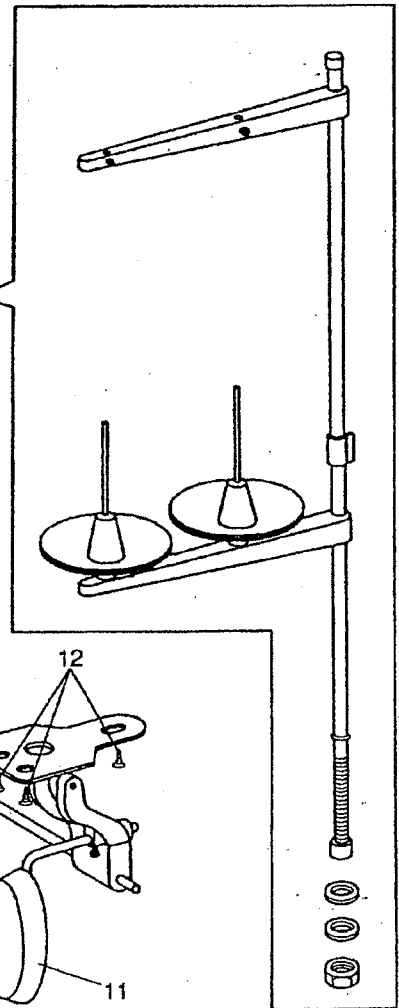
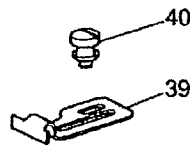
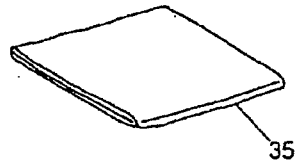
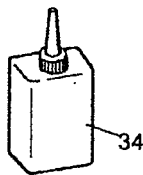
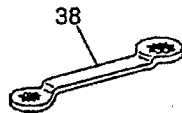
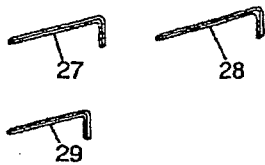
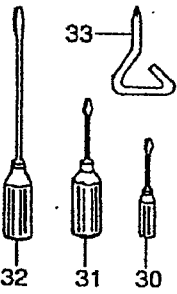
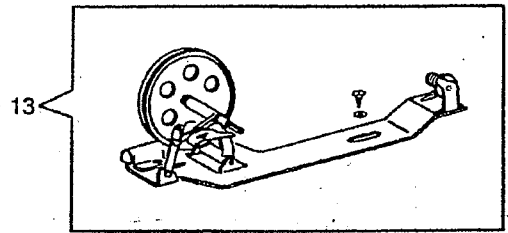
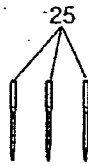
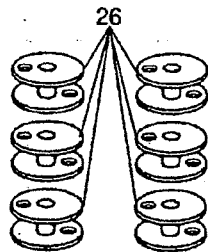
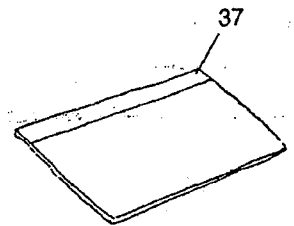
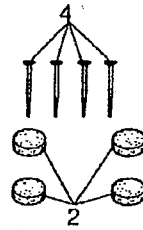
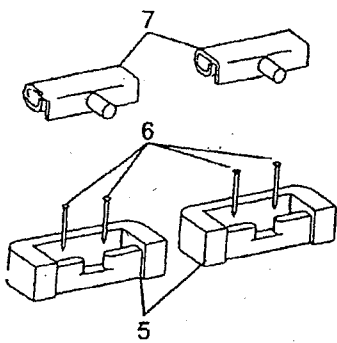

附属品

ACCESSORIES AND ATTACHMENTS

NO	部品番号 PART NO	数量 QTY	品名	PARTS NAME
1	35254	1	糸立てセット	THREAD UNWINDER COMPLETE
2	11887	4	ミシン受	MACHINE REST
3				
4	6055	4	釘	NAIL
5	11886	2	ミシンヒンジ受	MACHINE HINGE CONNECTION CUSHION
6	6055	4	釘	NAIL
7	11885	2	ミシン ヒンジ	MACHINE HINGE CONNECTION
8	10733	1	油受け	DRIP PAN
9	6055	4	釘	NAIL
10				
11	10735	1	ひざ上げセット	KNEE LIFTER COMPLETE
12	6052	3	木ねじ	KNEE LIFTER SCREW
13	10734	1	糸巻きセット	BOBBIN WINDER COMPLETE
25	N0122	3	針	NEEDLE
26	10656	6	ボビン	BOBBIN
27	10747	1	六角レンチ (1/16インチ)	WRENCH
28	11487	1	六角レンチ (3 ミリ)	WRENCH
29	11969	1	六角レンチ (2.5ミリ)	WRENCH
30	8121	1	ドライバー (小)	SCREW DRIVER (SMALL)
31	8120	1	ドライバー (中)	SCREW DRIVER (MIDDLE)
32	8118	1	ドライバー (大)	SCREW DRIVER (LARGE)
33	8180	1	十字ドライバー	SCREW DRIVER (CROSS TYPE)
34	8123	1	油差し	OILER
35	8124	1	ミシンカバー	MACHINE COVER
36				
37	8132B	1	補用品袋	ACCESSORIES PACK
38	10748	1	メガネレンチ	DOUBLE HEAD WRENCH
39	10730	1	定規	CLOTH EDGE GUIDE
40	10731	1	定規止めねじ	SCREW 13/64X32

www.southstarsupply.com

SAFETY

GUARDS

別売品

~~PARTS AVAILABLE AT EXTRA CHARGE~~

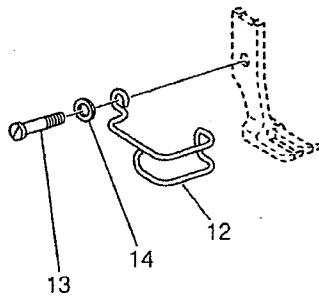
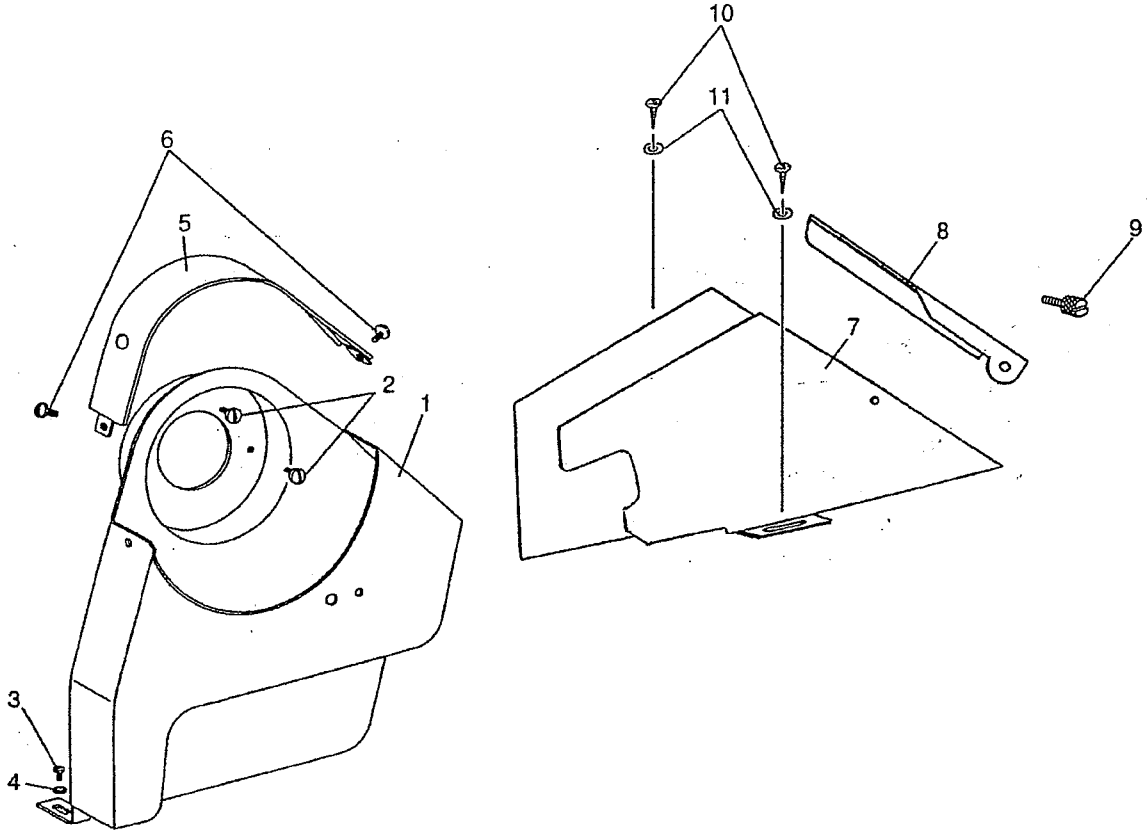

www.southstarsupply.com

別売品

PARTS AVAILABLE AT EXTRA CHARGE

NO	部品番号 PART NO	数量 QTY	品名	PARTS NAME
1	15098	1	ベルトガード	BELT GUARD
2	11162	2	止めねじ(上)	SCREW 3.4X36 L=5.4
3	10650	1	止めねじ(下)	SCREW 3.4X36 L=6.0
4	11142	1	ワッシャー	WASHER
5	15099	1	ベルトガード (上) カバー	BELT GUARD (TOP) COVER
6	12418	2	止めねじ	SCREW 13/64X32 L=9.0
7	15121	1	ベルトガード (下) カバー	BELT GUARD (BOTTOM) COVER
8	15122	1	ベルトガード (下) カバー (小)	BELT GUARD (BOTTOM) COVER (SMALL)
9	11830	1	止めねじ	SCREW 9/64X40
10	15081	2	木ねじ	SCREW
11	16287	2	ワッシャー	WASHER
12	10937-01	1	フィンガーガード	FINGER GUARD
13	10749	1	止めねじ	SCREW 3.4X36 L=11.0
14	10677	1	ワッシャー	WASHER

www.southstarsupply.com

Consolidated Sewing Machine Corp.

MAIN OFFICE

131 West 25th Street
New York, NY 10001
Tel: (212) 741-7788
Fax: (212) 741-7787

BRANCH OFFICE

7855 NW 29th Street, Bay 166
Miami, FL 33122
Tel: (305) 471-0200
Fax: (305) 471-0243

www.southstarsupply.com